

Workstation Cart

For use with SYSTEM 1®
Sterile Processing System



SYSTEM 1 is the leading low temperature system for the rapid, safe and standardized sterile processing of immersible surgical and diagnostic devices at or near the site of patient care.

The SYSTEM 1 Workstation Cart is a customized cart designed to organize SYSTEM 1 accessories and supplies for easy access and use. The cart ensures that STERIS 20 Sterilant Concentrate, JIT™ Processing Containers/Trays, Quick Connects and other supplies are all within easy reach of the Processor.

Features

- Two compartments for storing JIT Processing Containers/Trays
- Ample storage area for STERIS 20 Sterilant Concentrate
- Center drawer for organizing small items such as Quick Connects and monitoring supplies
- Pullout center shelf for convenient access to frequently used items
- Side mounted bin for storing the SYSTEM 1 Operator Manual
- Side mounted pre-filter assembly for easy installation and maintenance
- Steel welded construction for stable, sturdy support of the SYSTEM 1 Processor
- Durable surface finish for easy cleaning
- Large full-swivel locking casters for maneuvering into tight places
- Meets necessary standards and codes for use in O.R. (UL 544 and minimum OSHA requirements for stability)
- Ships completely assembled

STERIS®



SPECIFICATIONS

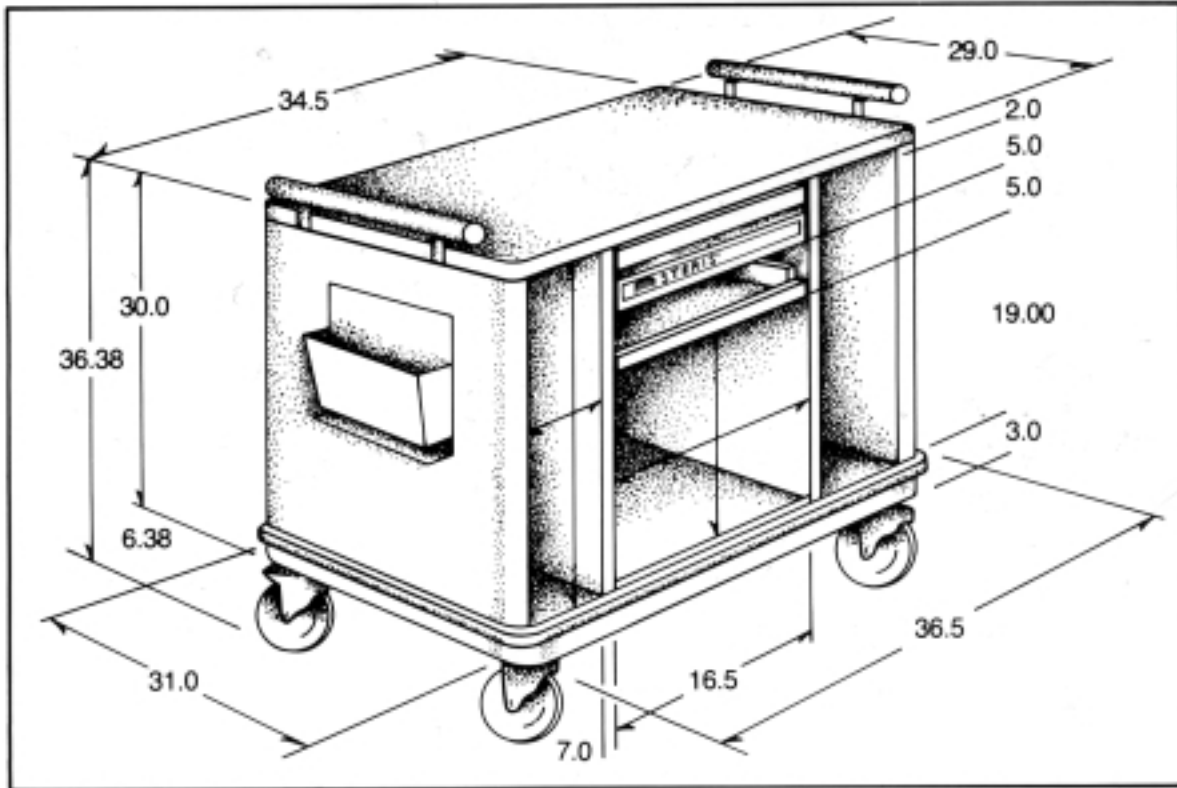

Width:	(Cart Only)	36.5 in.	(92.7 cm)
	(With Bin & Pre-filters)	45.5 in.	(115.6 cm)
Height:		36.4 in.	(92.5 cm)
Depth:		31.0 in.	(78.7 cm)
Weight:		225 lbs.	(102 kg)

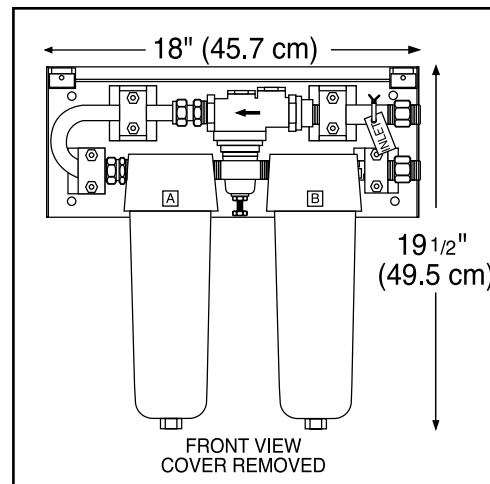

PREFILTER ASSEMBLY

STERIS Corporation is a leading provider of infection prevention, contamination prevention, microbial reduction, and surgical support systems, products, services, and technologies to healthcare, scientific, research, industrial customers, and government agencies throughout the world.

Manufactured exclusively by
STERIS Corporation in our
Mentor, OH facility which is ISO
9001, and ISO 13485 certified
by BSI.

Publication ID #M1013EN. 2004-09, Rev. E
GPSI Printed 9/2004, 5000
©2001-2004 by STERIS Corporation.
All rights reserved. Printed in USA

Technologies to Prevent Infection and Contamination™

STERIS OFFICES WORLDWIDE

Canada	800 661 3937
France	33 1 55 176000
Germany	49 2233 6999 0
Italy	39 02 2130341
Japan	81 78 321 2271
Korea	82 2 517 1517
Latin America	305 442 8202
Singapore	65 68 41 7677
Spain	34 91 658 5920
United Kingdom	44 1256 840400

STERIS®



STERIS Corporation
5960 Heisley Road
Mentor, OH 44060-1834 ■ USA
440-354-2600 ■ 800-548-4873
www.steris.com